TouchOpen for quick and easy access

The 800 TouchOpen Microwave with soft touch mechanism is the easiest way to access your food. With one action, the door opens quickly and smoothly, for seamless convenience.

Product Benefits & Features

TouchOpen for easy access

Our microwave with TouchOpen design gives you easy access to your food. The door opens seamlessly at the touch of a button, thanks to the specially designed soft mechanism. In one smooth movement you can enjoy quick access to dishes.

- Microwave for fully integrated built-in installation
- Built-in possibilities in combination with other appliances: Over oven
- Cooking modes: Microwave
- Electronic clock with timer
- Microwave power: 900 Watt, 5 levels
- Automatic cooking programs by weight
- Automatic defrosting programs by weight
- Child lock
- Quick start function at full power with 30 sec. intervals
- LED display
- Touch control power selection
- Internal light

Microwave - your kitchen shortcut

The microwave function is your shortcut to quick and delicious meals. At the touch of a button, you can melt chocolate, defrost your favourite casserole or re-heat leftovers, fast. It's the quick and easy way to create tasty meals.

Save microwave settings for your favourite dishes

Save your preferred microwave settings for quick and easy access with the Favourite function. Once you've created a programme, you can touch the star-shaped icon on the display to activate it. This means you don't need to remember any specific settings. It's all taken care of, at a touch.

A microwave ReTurntable that remembers where it started

We've designed this microwave oven so that dishes are always in the ideal position. This is because the door unlocks when the ReTurntable returns to where it started. No cup handles facing the wrong way, no hot plates in awkward positions. Just effortless access, every time.

Thaw your food quickly with our defrost function

Your frozen food is ready quickly, thanks to the microwave's defrost function. After you've selected the food type and weight, the microwave automatically calculates the time it will take. It then starts to thaw your dish while maintaining both the flavour and texture.

Product Specification

Nordic_Series_and_Themes	800 FLEX
Main colour	White
Dimensions HxWxD in mm	459x594x404
BI dimensions HxWxD in mm	450x562x500
Installation	FBI
DK_MC_GrossNet_capacity	26/25.37
Cavity material	Painted steel
Microwave output power W	900
Grill output power W	0
Power levels	5
Noise power in dB(A) - Top Oven.	60
Nordic_MW_AutoProgrammes	Automatic cooking and defrost programmes
Turntable diameter	325
Nordic_MW_Returntable	Yes
Voltage	220-240
Frequency	50
Required fuse (A)	10
Product Number Code	947 608 748
Bar code	7332543666157

PSGBMC220DE00002

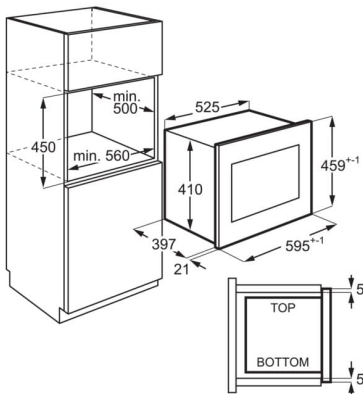

PSGBMC220DE00004

